

Introduction

The PIR-045 is a highly sensitive Passive Infrared Detector designed for detection outdoors with a narrow, curtain-shaped differential field of view. It incorporates microprocessor-controlled signal processing including signal shape analysis, adaptive threshold level by feedback of environmental effects, temperature compensation and rejection of disturbance signals.

Sensitivity adjustments are done with DIP-Switches for each individual unit in function of the required detection range in order to adapt to the specific needs of an installation.

In addition to the hardware settings, adjustments can be made in a two way communication mode and signals displayed on a PC screen by using the optional installation software and RS 485 communication interface module.

Mounting and Installation

The mounting structure should be stiff enough and resist to significant deflections in windy conditions. Movement of the PIR-045 caused by vibrations or other movements will result in swings of the field of view covered by the PIR-045 and could cause disturbance signals. These unwanted signals may lead to an increase of the alarm threshold level which reduces the detection probability or in certain cases can lead to unwanted alarms.

The universal bracket is equally suited for wall mounting (using screws) or pole mounting (using steel bands through the slots).

- It is very important that the cover of the PIR-045 is securely tightened. It must be tightened with the two screws to the point where it cannot be closed further with reasonable force. There will then be hardly any gap between the cover and the bottom part of the housing (considerably less than 1 mm).

The cable entry assembly should not be changed without authorisation by the manufacturer. It is specifically designed to allow air entry and exit so that the inside of the PIR-045 is always at atmospheric pressure. This prevents moisture being sucked into the PIR-045 by drop of internal pressure likely to happen when rainfall rapidly cools down a unit warmed up in the sun.

The nut on the cable entry assembly should be tightened to clamp the cable in place with the nylon grip. If the cable diameter is too small to be held by the grip, insulation tape should be wound around the cable to increase the outside diameter to a suitable size.

Connecting the PIR-045

For the definition of the connector board and terminal block see annex 1.

Alarm Signalling

There are three types of alarm signalling from the **PIR-045**:

- one SPST potential-free relay contact
- an open collector transistor to negative supply rail
- an RS 485 two way communication link (see annex 2 for details)

The relay contact opens and the transistor switches to low resistance on alarm.

Tamper Switch

To detect attempts to open the PIR-045, a tamper switch is fitted for the cover. Its contact opens when the cover is opened and should be connected in series with the normally closed relay contact.

Electronics Supply

Ensure that polarity is correct when connecting power to the electronic circuit. Protective circuitry will withstand a short period of reversed polarity, but damage will result if this is not corrected quickly.

Field of View

The PIR-045 has a curtain-shaped field of view with differential detection areas and a nominal range of 45 m (150 ft).

Alignment

The detection range of a PIR detector is not limited but a function of size, speed and temperature contrast of a target against its background. The PIR-045 should be aligned so that the field of view is terminated by a natural or artificial background at the end of the range.

Vertical alignment is optimal when the upper edge of the field of view is at 1.5 to 2.5 m above ground at the end of the required detection range provided that the field of view is properly terminated. Setting the overall sensitivity at less than 100 % does not limit the range but reduce the sensitivity where not needed.

Alignment can be done visually by looking along the groove on the top of the detector. This line of sight corresponds to the upper edge of the detection pattern.

Where the detection range has to be limited, a terminating screen can be used to avoid detection of targets beyond the wanted range (see annex 2).

Typical vertical alignment of PIR-045 for a required detection range of 45 m

The PIR-045 should be aligned vertically so that at least the lower half of a person standing upright at the maximum required range will be within the field of view (see Fig. 1 below).

Side view

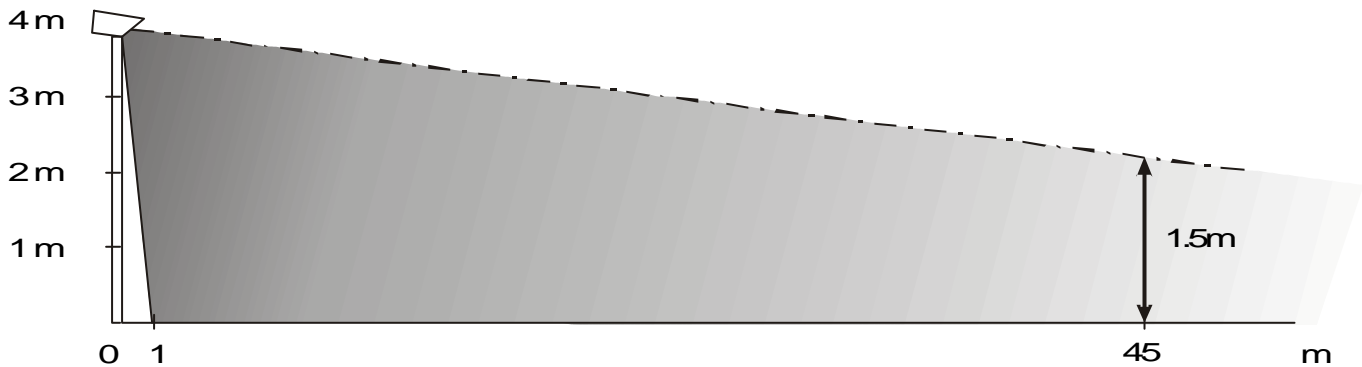

Fig. 1

Typical horizontal alignment of PIR-045

Horizontal alignment should be done in a way to avoid unwanted signals being generated by targets (branches, bushes, fences) likely to be moved by wind (see Fig. 2 below). Movement within the field of view will reduce the sensitivity of the PIR-045 by increasing the alarm threshold level and may lead to unwanted alarms.

Top view

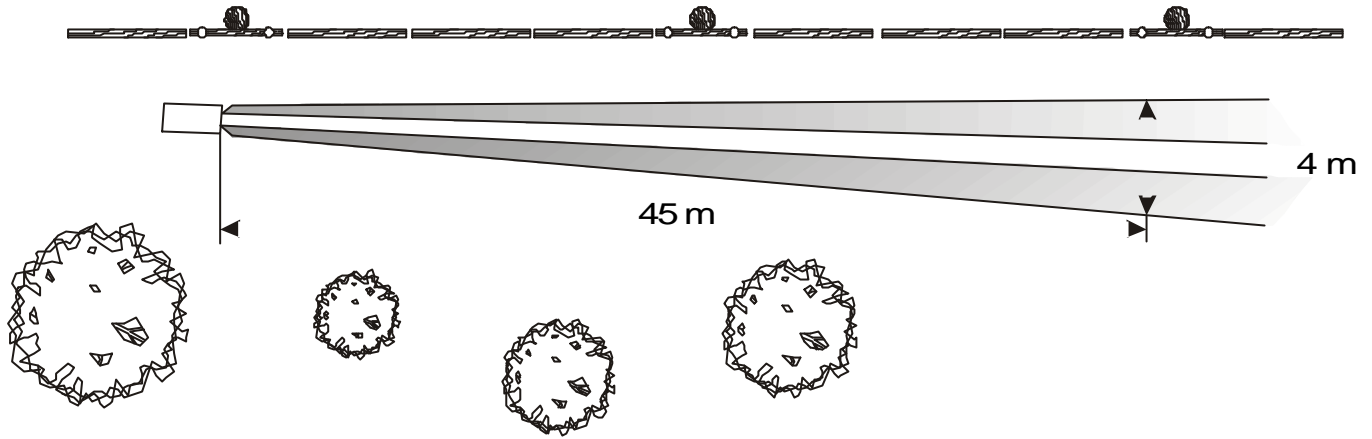

Fig. 2

- When walk testing the unit, the threshold level will increase as a result of the signal generated by the target and decrease exponentially in time after the event. To make sure that original sensitivity is reached, wait at least for 3 minutes between each crossing or disable the ATD function by setting DIP - Switch 3 to „off“.

If the Installation software is used for monitored walk tests and the DIP – switches 1 and 2 are set to software settings (on – on), the nominal threshold level can be reset by pressing [n]. Alternatively the threshold level can be kept to its minimum value by changing the configuration of the ATD for this test (see annex 3 for details).

Sensitivity Settings

The various settings of the PIR-045 are made by means of multiple DIP - switches on the connector board.

The **DIP – Switches 1 and 2** are for **sensitivity setting** depending on the required detection performance. If the maximum required range is less than the nominal range of the detector, it is recommended to reduce the overall sensitivity to reduce nuisance alarms.

Switch 1 and 2	Overall Sensitivity
off – off	40 %
off – on	75 %
on – off	100 %
on – on	Software Settings

*) 20 ... 140 %

*) With the DIP - switches 1 and 2 both set to „on“, the overall sensitivity is 100% factory setting but can be changed with the installation software (see annex 3 for details).

If the sensitivity is adjusted with the installation software, the programmed value will remain active also following a power off.

Operation of the PIR-045 with overall sensitivity set to more than 100% is not recommended in outdoor applications as the nuisance alarm rate could increase significantly.

Adaptive Threshold Discrimination (ATD)

The background noise is constantly averaged and used to adjust the threshold levels for the alarm. This special feature is reducing the probability of nuisance alarms caused by wind, moving vegetation or objects that have a thermal contrast although usually weaker than a person.

Each signal exceeding a certain minimum value will activate the ATD and increase the threshold levels depending on its strength. The time constants for increase and decrease are chosen in a way to adapt to gradual changes. Signals generated by a person moving within the specified speed range, however, are fast enough for detection.

Repeated movement of any kind within the field of view is therefore activating the ATD, reducing the overall sensitivity. This has to be noted particularly when walk testing the PIR-045 following installation.

The **DIP – Switch 3** is used to activate or deactivate the **ATD** (Adaptive Threshold Discrimination), for details of the ATD function see below.

Switch 3	ATD
off	„Off“
on	„on“

*)

*) Operation of the PIR-045 in this mode is possible but not recommended in outdoor applications as the nuisance alarm rate could increase significantly as a result of turbulences.

The **DIP – Switch 4** has no function in this detector model.

Alarm Time

Alarm time and count per event is determined by the duration of the detected event and depends on the shape and amplitude of the alarm signal. Individual alarm pulses have a minimum time of app. 2.0 s.

Internal Temperature Compensation

The PIR-045 is detecting radiation differences of a target against its background. In the course of the day and year the contrast of a person will vary considerably and affect the signal strength. To compensate for this contrast variation, the PIR-045 has internal temperature compensation with maximum sensitivity at app. 30°C (where the contrast of a human target is weakest) and gradual reduction at higher and lower temperatures.

- When installing a unit the internal temperature may take up to 30 minutes or more to stabilise to the actual external temperature. Sufficient time should be given to the PIR-045 to reach the correct internal temperature and sensitivity before performing walk tests.

During the initial period of operation it is strongly recommended that walk tests are repeated and signals monitored under various weather conditions such as high and low temperatures, wind fog, snow, rain etc. to obtain comparative data and information on the effects of environmental conditions on detection and nuisance alarm probabilities for this particular site. Fine-tuning of the detector based on this data by changing the sensitivity settings may optimise the performance.

External Sensitivity Adjustment via RS 485 Data Bus

If the **DIP - Switches 1 and 2** are both set to „on“, the detection performance can be adjusted via the RS 485 two way communication port. Overall sensitivity of the PIR-045 can be set to any value between 20 and 140 %.

The external sensitivity adjustment may also be used if overall sensitivity has to be changed at certain periods of the day or year depending on the prevailing thermal contrasts. Field tests in the actual environment will determine the optimum settings. For further details refer to annex 3.

Signal Processing

The background noise is sampled at a rate of app. 400 per second and averaged over a large number of cycles giving a noise dependent value for the alarm threshold and to start the signal shape analysis whenever a certain amplitude value is exceeded.

If the threshold has temporarily been increased by high background noise or repeated movements in the field of view, the exponential decay of the threshold level to its original value will take app. 1... 2 minutes from the end of the event.

Once the first threshold level value has been exceeded, the microprocessor starts its signal shape analysis routine where a number of interdependent parameters including peak amplitude, rate of rise, time windows and overall shape are calculated and analysed.

If the rate of rise of the signal is too high, as may happen as a result of RF interference, lightning, shock waves or birds flying across the field of view close to the unit, a possible alarm will be rejected. This means also that a very fast movement directly in front of the detector may not lead to an alarm even though the amplitude would be large enough.

Only if a signal meets all the predetermined criteria an alarm will be generated.

Interface Module PIR-IF485A and Installation Software

The Installation Software is very useful for alignment and signal check during setting up and routine maintenance. It will indicate the amplitudes generated by wanted as well as unwanted targets and help setting the gain control correctly during walk tests and also show the magnitude of disturbance signals. The installation software is to be installed on a PC; an interface module is required to convert RS 232 to RS 485. The information for installation and signal monitoring is displayed on the screen of the PC. Refer to annex 3 for more details.

If more than one detector is connected to the same RS 485 communication bus, each detector needs to have a different identification number.



The interface module PIR-IF485A is available as an accessory and is pre-configured and equipped with the necessary connectors to be operated with any detector of the IR 450 Series without the need for external power supply or other connections.

The input cable is 4.0 m long and is terminated with a connector fitting into the test socket on the connector board of the detector.

The connection to the PC's COM port is with a standard 3.0 m cable (supplied with the PIR-IF485A).

Total weight of the PIR-IF485A with cables is app. 400g.

Maintenance

The detector has been designed to be virtually maintenance free but the following precautions are recommended:

- 1) **Visual inspection of the front window** for accumulation of dirt on the outer surface or damage at intervals of app. 6 months. Clean the surface with a paper tissue and avoid rubbing dirt into the surface. Use the same precautions as for a camera lens.
- 2) **Visual inspection of the inside** for ingress of water is recommended at intervals of 6 to 12 months or whenever the unit is opened for adjustments or tests. Make sure that the sealing gasket is in place before closing the cover tightly again.
- 3) **Inspection is recommended following extreme conditions** such as snow storms, sand storms, hail etc. to make sure that nothing has been damaged and the sensitivity is not reduced by accumulation of snow, sand or dirt on the front window. Snow or dust in front of the window should be removed by hand or by using of a soft instrument (e.g. a wooden stick).

General Comment on the PIR-045

- Despite the advanced design and state-of-the-art features of the PIR-045 it is in the nature of a Passive Infrared Detector that an absolute detection probability and freedom from nuisance alarms cannot be achieved, masking of the PIR-045 cannot be excluded.
- Detection is a function of thermal contrast, speed and size of a target crossing the field of view. Contrast conditions can vary significantly in the course of the day and year.
- Detection depends also on the sensitivity settings, the exact aiming and the prevailing weather conditions as well as the nature of the target and background.
- The detection pattern and frequency response of the PIR-045 has been optimised for the detection of human size targets crossing the field of view in an upright position at speeds in the range of 0.2 ... 5.0 m/s.
- Detection of slow moving targets at long range may become uncertain under weak contrast conditions. It is strongly recommended to limit the zone length to less than the nominal range when human targets moving at the minimum specified speed need to be detected with high probability.
- Animals or crawling people may or may not be detected depending on their size, speed, contrast and distance from the PIR-045.

It is therefore strongly recommended to combine the PIR-045 with an alarm verification such as CCTV or a second system using other physical means of detection (e.g. VMD).

Any liability for direct or indirect damage resulting from the use of the PIR-045 as a detection device is explicitly disclaimed.

The information in this product manual is based on testing of samples taken at random from production and believed to be representative, E&OE.

Annex 1: Connector Board and Terminal Block

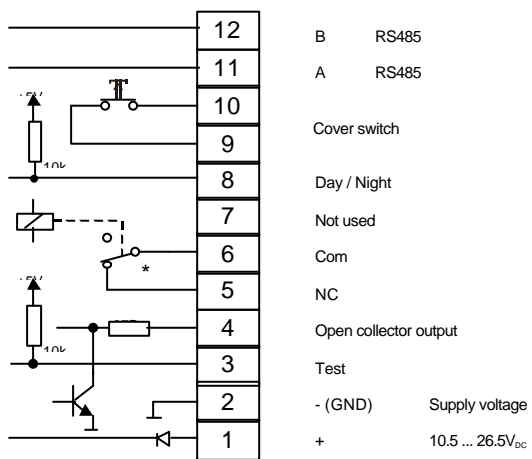
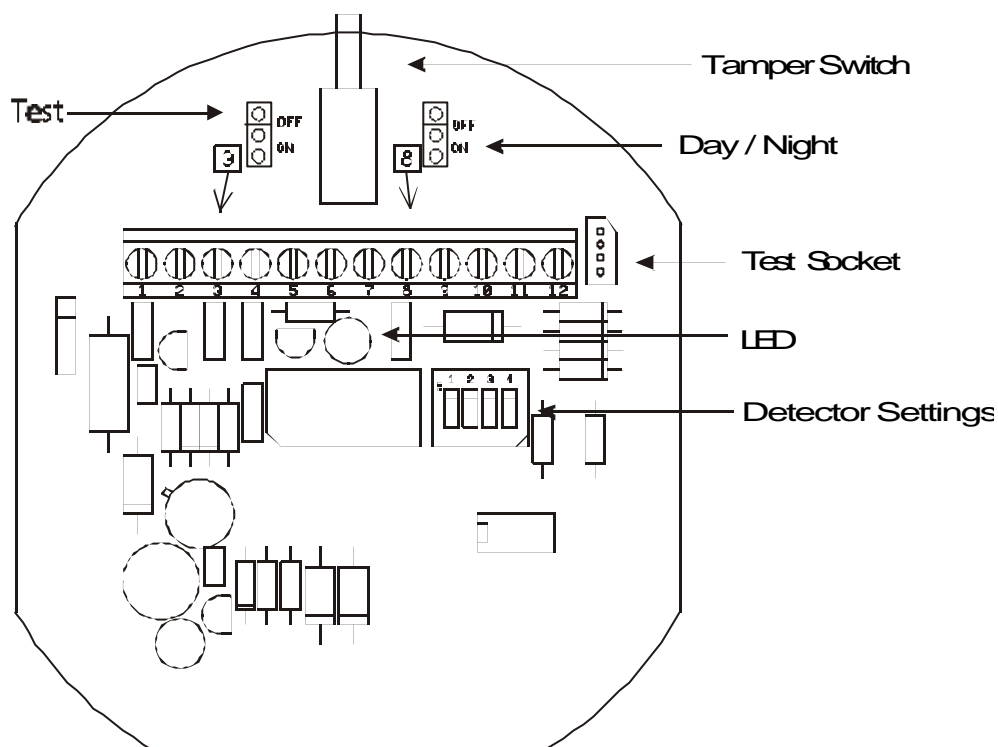

* Relay shown in energised (non-alarm) condition

Control Inputs

Day / Night	Test	Detector Function	LED
Night	ON	Walk test indication	LED enable
Night	OFF	Memory set enable	LED disable
Day	OFF	If memory was set	LED flashes 2 Hz
Day	ON	Walk test indication	LED enable
Night ON	X	Memory reset	LED stop flashing

Test 3

OFF: Input open
ON: Input pulled to (-)

Day / Night 8

Night: Input open
Day: Input pulled to (-)

Annex 2: Two Way Communication RS 485

Introduction

The PIR-045 is equipped with a RS 485 interface for two-way communication between the detector and a PC or other control device. This communication link is used for detector set-up and remote adjustments as well as for signal monitoring (see also annex 3).

It can either be used temporarily for installation or permanently wired for remote access to the detector from the control room. RS 485 can accommodate up to 32 detectors on the same data bus with a maximum bus length of 1'000 m – provided the detectors have all different ID's and the data link is properly terminated. If in doubt consult the manufacturer.

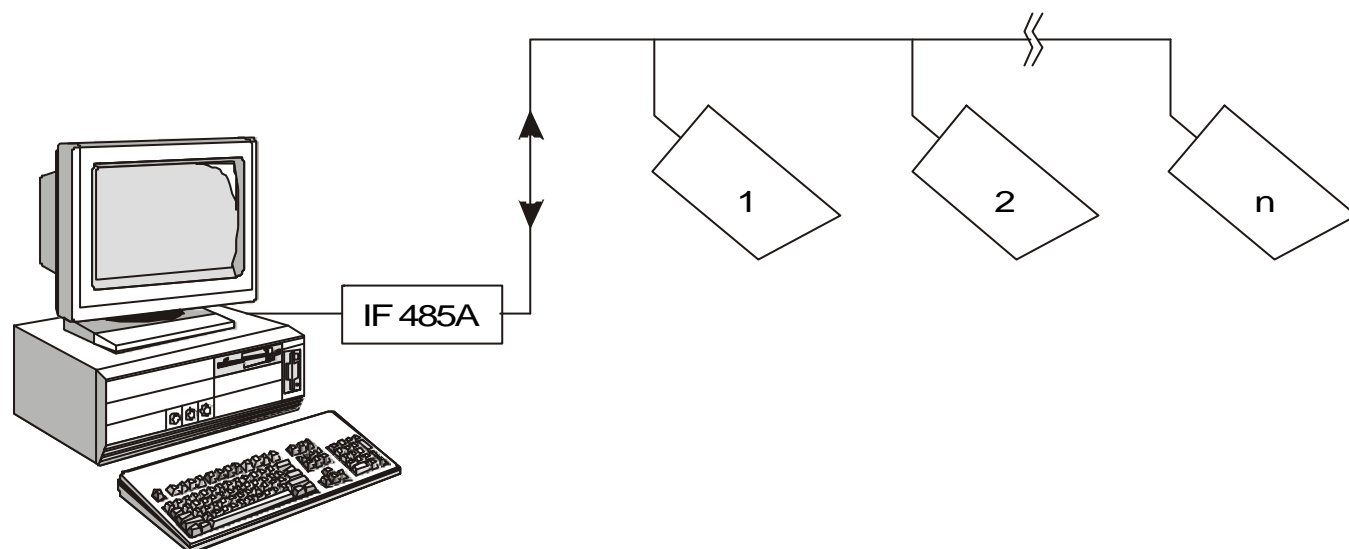

Temporary Connection for Installation and Configuration

For this, the use of the interface module PIR-IF485A is recommended (see section 12. above). The test socket carries V+, GND and the two RS 485 ports A and B. The detector needs to be opened for access to the test socket and closed again after the adjustments. All the adjustments and display functions as detailed in annex 3 are possible without further equipment.

Installation and Configuration for Permanent Wiring

For permanent connection of the RS 485 communication link to a control room the two RS 485 ports A and B are also accessible on the terminal block. The connector board contains all components required for protection of the communication link.

In this mode it is not only possible to do all adjustments and signal monitoring remotely from the control room but also eventually to use the RS 485 link for alarm signalling.

When planning to use the PIR-045 in this configuration please consult the manufacturer for details about the protocol definitions.

Annex 3: Installation Software

Introduction

The installation software is available as accessory for alignment, setting up and fault finding and can be used with all detectors of the IR 450 Series. It is recommended for verification of all installations in order to optimise the performance of the detectors and can be used for remote programming and verification of all detectors connected to the same RS 485 data bus.

A converter RS 232 to RS 485 is required for operation with a standard PC.

The following describes the features of the installation software program for remote programming and signal display.

Application of the Installation Software

The installation software is a most useful tool for checking the alignment and sensitivity setting of the detectors. It greatly facilitates the optimisation of an installation to suit a particular site.

The software is particularly helpful in situations where a detector is operated under conditions near the recommended operating limits of height, detection range and target speeds. The information supplied by the PC display should be used to monitor the detection performance of the detector and make adjustments if required.

Depending on the site's animal activity, vegetation moving in the wind and/or other sources of disturbance it is possible that unwanted alarms occur. Monitoring and interpreting the information supplied by the installation software will help finding the best solution either by adjusting the alignment and/or sensitivity of the detector or by removing disturbance sources from within the field of view.

Installation Software for PIR-045

Procedure

- Connect the PIR-045 to power and connect the interface module to the detector's test socket or the terminal block as defined in annex 1.
- Connect the output of the interface module with the serial COM port of the PC
- Exit „Windows“ and **start PC under DOS**
- Load file installation program (INST45XC.EXE), enter language and number of COM port

Main Menu IR 45X

The Main Menu offers the following options:

[F1] Scanning (range 1 ... 20)

- Pressing **[F1]** initiates a search for all detectors with different ID numbers within the defined range, which are connected to the same RS 485 data bus.
- After successful search all detectors found are listed in the table with their model, and version.

[F2] Scan Range (any value from 1 ... 254 for start and stop addresses)

- Depending on the ID numbers of the detectors, the start and stop addresses can be varied.

[F3] Configuration (Remote Programming)

For remote programming the DIP - Switches 1 and 2 need to be set to position „on“

- Press **[F1]** and select the detector to be programmed using the arrow keys.
- Adjust the parameters as required within the range indicated on the display.

[F4] Scope

Fore remote display of signals for the detector selected in the main menu

- The left part of the screen displays the analog signal, two of the alarm thresholds and the alarm status (on - off).
- On the right, all relevant information of the detector is displayed in text form.
- The following keys can be used for specific purposes
 - **[pause]** to freeze the display
 - **[space]** to clear the screen
 - **[s]** for PC sound on or off
 - **[h]** to save a hardcopy of the screen display as a bitmap in the active directory. A file will be generated and saved as „DDMMYYAB.BMP“ where AB is used for identification of files within one day. This function is not possible when the display is frozen.
 - **[n]** to reset the thresholds to the minimum value. This key should be pressed prior to each walk test to make sure the detector is at its nominal sensitivity.

Notes

- When walk testing the PIR-045 make sure to **disable the ATD or to reset it by pressing [n] before each walk test**, otherwise the detection will become poor due to gradual increase of the thresholds.
- For **software programming** the **DIP - Switches 1 and 2** need to be set to position **on – on**
- Running „INST45XC.EXE“ under Windows may lead to problems therefore exit Windows and **start computer under DOS** to run the program.

Typical Display of Scope Function

