

INSTALLATION INSTRUCTION

1. Introduction

The PIR-150 is a highly sensitive Passive Infrared Detector designed for long range detection outdoors with a narrow, curtain-shaped differential field of view. It incorporates adaptive threshold discrimination by feedback of environmental effects and rejection of disturbance signals, temperature compensation, flat frequency response and a computer designed optical system for uniform curtain coverage.

The gain can be adjusted with a potentiometer to adapt the sensitivity of each individual unit in function of the required detection range and according to the specific needs of an installation. Depending on the type of installation, emphasis can be put on maximum detection or lowest nuisance alarm probability.

2. Mounting and Installation

The mounting structure should be stiff enough to resist significant deflection in windy conditions. Movement of the PIR-150 caused by vibrations or other movements will result in large swings of the field of view covered by the PIR-150 and could cause strong disturbance signals. These unwanted signals may lead to an increase of the alarm threshold level thus reducing the responsiveness or in certain cases producing unwanted alarms.

- It is very important that the back cover of the PIR-150 is securely tightened. It is not sufficient to close the cover only to the point where the O - ring starts to rub against the inside of the cover. It must be tightened to the point where it cannot be closed further with reasonable force. There will then be hardly any gap between the cover and the housing (considerably less than 0.5 mm).

The cable entry assembly should not be changed without authorisation by the manufacturer. It is specifically designed to allow air entry and exit so that the inside of the PIR-150 is always at atmospheric pressure. This prevents moisture being sucked into the PIR-150 by drop of internal pressure likely to happen when rainfall rapidly cools down a unit warmed up in the sun.

The nut on the cable entry assembly should be tightened to clamp the cable in place with the nylon grip. If the cable diameter is too small to be held by the grip, insulation tape should be wound around the cable to increase the outside diameter to a suitable size.

3. Connecting the PIR-150

For the definition of the connector board and terminal block see Annex 1.

Alarm Signalling

There are two types of alarm signalling from the PIR-150:

- one set of SPDT potential-free relay contacts
- an open collector transistor to negative supply rail

The relay contact changes state and the transistor switches to low resistance on alarm.

Tamper Switch

To detect attempts to open the PIR-150, a tamper switch is fitted for the rear cap. Its contact opens when the cap is unscrewed and can be connected in series with the normally closed relay contact if no separate tamper line is used.

Electronics Supply

Ensure that polarity is correct when connecting power to the electronic circuit. Built-in circuitry will withstand a short period of reversed polarity, but damage will result if this is not corrected quickly.

4. Field of View

The PIR-150 has a curtain-shaped field of view formed by differential detector zones for long to short range detection. Their relative sensitivity is balanced in function of their respective range for the recommended mounting height of 2.5 to 4.0 m. The vertical opening angle is app. 25° resulting in an uninterrupted curtain starting at app. 8 m with the PIR-150 mounted at 4.0 m height and aligned for a detection range of 100 m (Fig. 1).

The mounting should be done in a way to allow easy horizontal and vertical alignment while giving the required long term stability.

5. Alignment

The detection range of a PIR detector is not limited but a function of size, speed and temperature contrast of a target against its background. The PIR-150 should be aligned so that the field of view is terminated by a natural or artificial background at the end of the range.

Where a terminating screen is used its surface should not be glossy to avoid reflected images from outside the field of view. Also the material may be transparent for visible light but it has to block thermal radiation; wood, poly-carbonate and acrylic are suitable materials.

Effectiveness of a screen has to be checked by walk testing around the screen. Signals from walk tests in front of the screen should still be strong while movements behind the screen should result in signals well below the threshold level. If walk tests or vehicles passing behind the screen are strong enough to trigger an alarm the PIR-150 should be tilted slightly downward. The Installation Tester IT 44 gives accurate information about signal strengths during a test.

Coarse alignment can be done visually by looking along the groove on top of the detector. Accurate fine alignment is easily achieved with the help of the Universal Telescopic Sight ZA P 03 which can be placed on top of the PIR-150 for this purpose.

The graticule of the ZA P 03 corresponds to the axis of the detector. The detection curtain extends from + 1.2° to - 25° in the vertical plane from the axis of the detector. Table 1 shows the elevation (Z) of the upper edge of the field of view from the axis and the total width (Y) of the field of view as a function of the actual distance from the PIR-150.

Distance X	Total width Y	Elevation Z
25 m	0.6 m	0.5 m
50 m	1.3 m	1.0 m
75 m	1.9 m	1.5 m
100 m	2.5 m	2.0 m
125 m	3.1 m	2.5 m
150 m	3.7 m	3.0 m

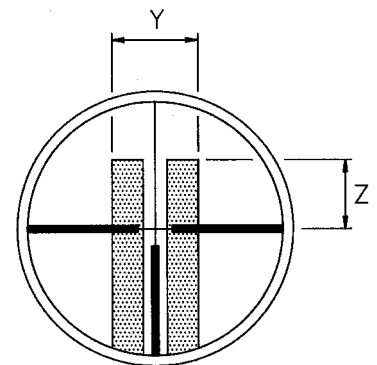

Table 1

Note: The dimensions „Y“ and „Z“ are calculated figures verified by experiments. Actual dimensions will vary with contrast conditions.

Typical vertical alignment for a required detection range of 100 m

The PIR-150 should be aligned vertically so that at least the lower half of a person standing upright at the maximum required range will be within the field of view (see Fig. 1 below).

Side view

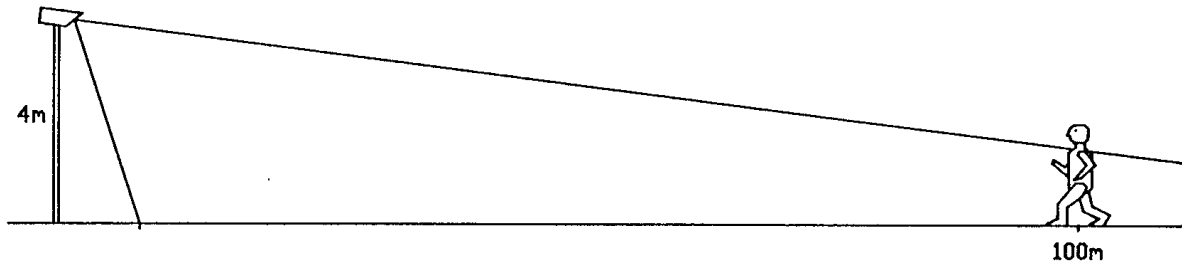

Fig. 1

Typical horizontal alignment

Horizontal alignment should be done in a way to avoid unwanted signals being generated by targets (branches, bushes, fences) likely to be moved by wind (see Fig. 2 below). Movement within the field of view will reduce the sensitivity of the PIR-150 by increasing the alarm threshold level or may lead to unwanted alarms.

Top view

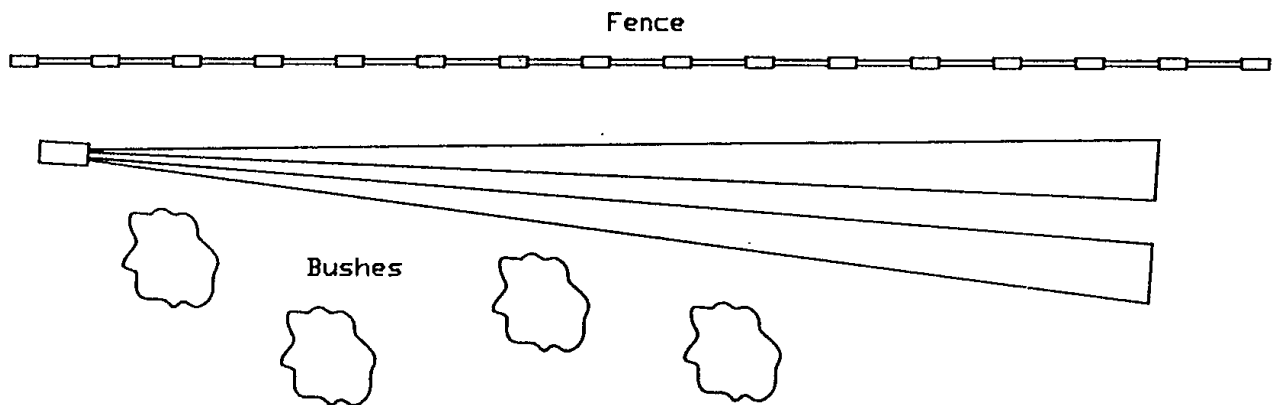

Fig. 2

The ZA P 03 alignment telescope is a convenient alignment aid giving a high degree of accuracy for initial installation. It is nevertheless important to verify correct alignment by monitored walk tests across the field of view.

- When walk testing the unit the threshold level will increase as a result of the signal generated by the target. To make sure that original sensitivity is reached, wait at least for 1 minute between each crossing or disable the Adaptive Threshold Discriminator (ATD) by closing the switch on the connector board.

If the Installation Tester IT 44 is used for monitored walk tests, the instantaneous threshold level will be displayed.

6. Sensitivity Adjustment for Range

The sensitivity of the PIR-150 is adjusted by means of a potentiometer with an adjustment range from 20 to 140 % of nominal sensitivity. It is normally not recommended to set the gain adjustment higher than 100 % even for the full range unless an increased number of nuisance alarms can be tolerated in exchange for a maximum detection probability.

The PIR-150 is designed to detect human targets to distances up to 150 m under most environmental conditions. For an optimum detection to nuisance alarm ratio it is recommended to limit the detection range to 100 m and set the gain to app. 80% of nominal (factory setting).

Recommended settings of the sensitivity gain control as a function of required detection range are shown in Table 2 and are as follows:

Potentiometer Setting	Detection Range
70 - 140 %	100 to 150 m
50 - 100 %	80 to 100 m
40 - 80 %	60 to 80 m
30 - 60 %	40 to 60 m
20 - 40 %	30 to 40 m

Table 2

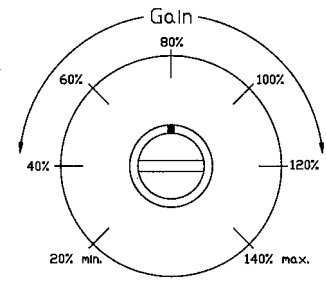

The PIR-150 is designed for mounting at heights between 2.5 and 4.0 m above ground. Lower or higher mounting will lead to sub-optimal balance of the detection curtain and lead to detection gaps or excessive nuisance alarms.

Vertical alignment is optimal when the upper edge of the field of view is at 1.5 to 2.5 m above ground at the end of the required detection range provided that the field of view is properly terminated. Setting the detection range as specified above does not limit the range but reduces the sensitivity of the whole curtain. Targets moving at the lower limit of the specified speed at the end of the range will produce relatively weak signals.

7. Alarm Time

The alarm time depends on the shape and amplitude of the alarm signal and can be as short as app. 0.2 s. If a signal is very strong the PIR-150 may generate a longer or several alarm pulses for the same event.

If required by the application the alarm time can be extended by up to 10 seconds per event with a potentiometer on the connector board.

8. Internal Temperature Compensation

The PIR-150 is detecting radiation differences of a target against its background. In the course of the day and year the contrast of a person will vary considerably and affect the signal strength. To compensate for this contrast variation, the PIR-150 has an internal temperature compensation with maximum sensitivity at app. 30°C (where the contrast of a human target is weakest) and gradual reduction at higher and lower temperatures.

- When installing a unit the internal temperature may take up to 30 minutes or more to stabilise to the actual external temperature. Sufficient time should be given to the PIR-150 to reach the correct internal temperature and sensitivity before walk tests are done.

During the initial period of operation it is strongly recommended that walk tests are repeated and signals monitored under various weather conditions such as high and low temperatures, wind fog, snow, rain, etc. to obtain comparative data and information on the effects of environmental conditions on detection and nuisance alarm probabilities for this particular site.

9. Adaptive Threshold Discrimination (ATD)

The background noise is constantly averaged and fed into a special circuit changing the threshold level for the alarm. This special feature is reducing the probability of nuisance alarms caused by wind, moving vegetation or objects which have a thermal contrast although usually weaker than a person.

Every signal exceeding a certain minimum value will activate the ATD and increase the threshold level depending on its strength. The time constants for increase and decrease are chosen in a way to adapt to gradual changes. Signals generated by a person moving within the specified speed range are fast enough for detection but will activate the ATD circuit as well. Repeated movement of any kind within the field of view is therefore activating the ATD, reducing the overall sensitivity.

This has to be noted particularly when walk testing the PIR-150 following installation. For this purpose, the ATD circuit should be disabled by closing the corresponding switch on the connector board. Operation of the PIR-150 in this mode is possible but not recommended in outdoor applications as the nuisance alarm rate would increase significantly.

10. Internal Heater

A regulated heater which can be connected to the supply voltage of the PIR-150 or a separate DC or AC supply of 12 to 24 Volts nominal prevents the optical surfaces from fogging or frosting and maintains the internal temperature at optimal levels. It is highly recommended always to operate the PIR-150 with the heater connected as temporary loss of sensitivity or permanent damage could result from condensation inside the detector.

11. Installation Tester IT 44

The Installation Tester IT 44 is very useful for alignment and signal check during setting up and routine maintenance. It will indicate the amplitudes generated by wanted as well as unwanted targets and help setting the gain control correctly during walk tests and show the magnitude of disturbance signals.

The information displayed on an LCD once the Installation Tester is connected to the detector includes bar display of signal amplitudes with peak hold feature, instantaneous threshold level as well as alarm time and count. A separate description is available with more details.

12. Maintenance

The detector has been designed to be virtually maintenance free but the following precautions are recommended:

- 1) **Visual inspection of the front window** for accumulation of dirt on the outer surface or damages at intervals of app. 6 months. To clean the surface use a paper tissue and avoid rubbing dirt into the surface. Use the same precautions as for a camera lens.
- 2) **Visual inspection of the inside** for ingress of water is recommended at intervals of 6 to 12 months or whenever the unit is opened for adjustments or tests. Make sure that the sealing rings are in place before closing the back cover tightly again.
- 3) **Inspection is recommended following extreme conditions** such as snow storms, sand storms, hail etc. to make sure that nothing has been damaged and the sensitivity is not reduced by accumulation of snow, sand or dirt on the front window. Snow or dust in front of the window should be removed by hand or the use of a soft instrument such as a wooden stick.

13. General Comment on the PIR-150

- Despite the advanced design and state-of-the-art features of the PIR-150 it is in the nature of a Passive Infrared Detection System that an absolute detection probability and freedom from nuisance alarms cannot be achieved, *masking of the PIR-150 cannot be excluded*.
- Detection is a function of thermal contrast, speed and size of a target crossing the field of view. Contrast conditions can vary significantly in the course of the day and year.
- Detection depends also on the sensitivity settings, the exact aiming and the prevailing weather conditions as well as the nature of the target and background.
- The detection pattern and frequency response of the PIR-150 have been optimised for the detection of human size targets crossing the field of view in an upright position at speeds in the range of 0.2 ... 5.0 m/s.
- Detection of slow moving targets at long range may become uncertain under weak contrast conditions. It is strongly recommended to limit the zone length to max. 100 m when human targets moving at the minimum specified speed need to be detected with high probability.
- Animals or crawling people may or may not be detected depending on their size, speed, contrast and distance from the PIR-150.

It is therefore strongly recommended to combine the PIR-150 with an alarm verification such as CCTV or a second system using other physical means of detection.

Any liability for direct or indirect damage resulting from the use of the PIR-150 as a detection device are explicitly disclaimed.

The information in this product manual is based on testing of samples taken at random from production and believed to be representative.

14. Specification:

Nominal Range:	100m (330 ft)
Spectral Response:	8-14 micrometres, double filtered
Sensor:	Differential pyro-electric array
Alarm Output:	SPDT relay, 3W, 0.25A, 28VDC/20VAC Transistor, NPN open collector, 20mA/30V
Output Protection:	PTC resistor
Alarm Indicator:	Internal LED
Alarm Hold Time:	0.2-10 seconds, adjustable
Sensitivity Adjustment:	20-140% of nominal
Temperature Compensation:	Gain control 40-100%
Target Speed:	0,2 – 5 m/sec.
Internal Switches:	Adaptive threshold system on/off
Supply Voltage:	10.5 to 28 VDC (nominal 12VDC)
Supply Current:	Typ. 20 mA at 12VDC (without heater)
Heater Power:	Approx. 1 W at -40°C
Operating Temperature:	-40°C to 60°C (-40°F to 140°F)
Sealing:	Splash proof to IP64 (cable entry spray proof to IP53)
Weight:	1.2 kg (2.6 lbs)
Dimensions:	314mm long x 89mm diameter (13" x3.5")
Cable Feedthrough:	Cable diameter 6-14mm (PG16)
Cable Termination:	Screw terminals
Mounting:	UBP-150, Universal mounting bracket (optional)
Test Socket:	For connection to IT44 Install. Tester

Annex 1: Connector Board and Terminal Block

The relay is shown in energised, non - alarm state.

ATD is activated when switch is open (close switch for walk tests only!)

Connector Board

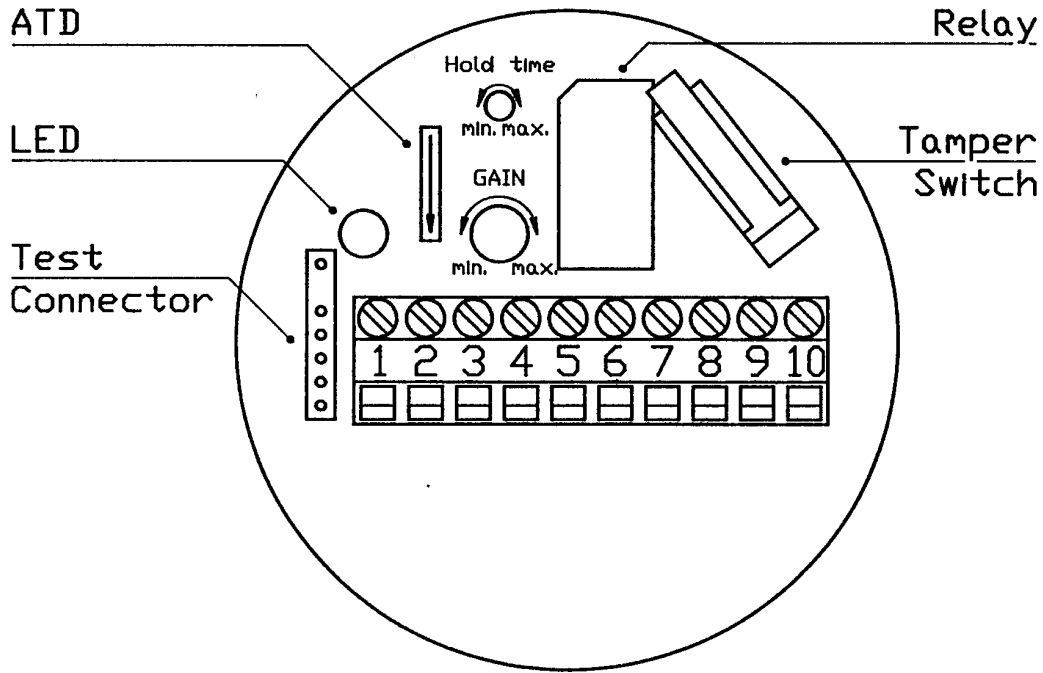

Terminal Block

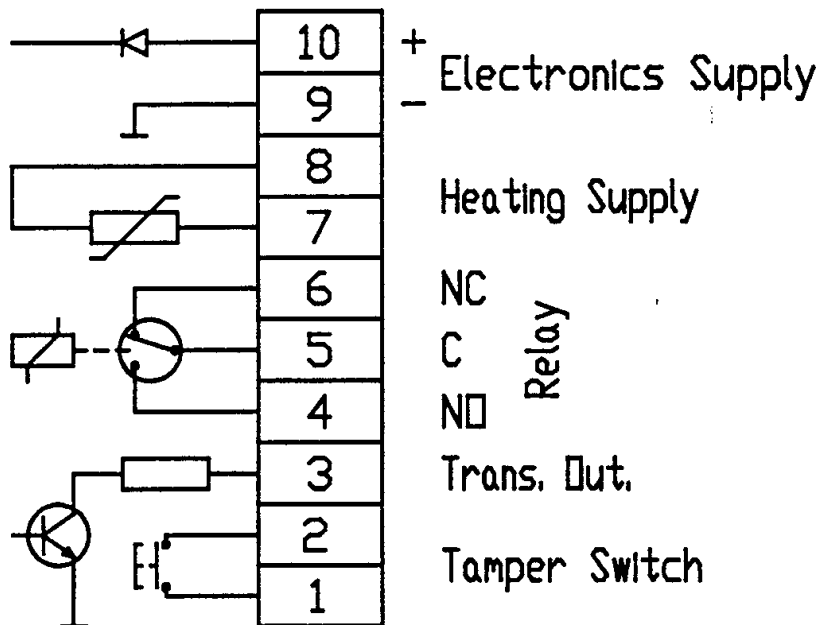

Annex 2: Instructions for Terminating Screens and Ground Surface

Introduction

The detection range of a PIR detector is not limited but a function of size, speed and temperature contrast of a target against its background. Alignment of the detectors should be carried out in such a way that the field of view is terminated by a natural or artificial background at the end of the range. Reflections from inside or outside the field of view have to be avoided as well as possible.

Definition of Field of View

The numbers stated in the technical manual for the vertical and horizontal dimensions are defined – per the usual standards – as the half power points representing 50% of the relative sensitivity at that distance for a typical human target. Absolute signal amplitudes depend on temperature contrast, speed and size of a target and can be up to 20 times (and more for large vehicles) higher than the alarm threshold. For a strong signal the dimensions will appear to be increased compared to the nominal values. This needs to be considered when dimensioning a terminating screen.

Dimensioning a Terminating Screen

From the field of view definition it becomes clear that the width of a terminating screen has to be larger than the actual figures given in the technical manual, this particularly when a street crosses the field of view behind the screen.

A practical factor for the width of a screen is **1.5 times the width Y** of the field of view at the distance from the detector.

The considerations for the vertical dimension are similar although a certain installation flexibility is given by tilting the unit slightly downward with the risk of losing sensitivity in the uppermost part of the curtain. Therefore it is recommended to extend the screen also vertically in the same way using the same factor of **1.5 times the elevation Z**.

Example: Screen at 100 m for a curtain height of 4 m with a PIR-150 (see Table 1)

Width Y	2.5 m	Screen Width	3.75 m
Elevation Z	2.0 m	Screen Height Above Axis	3.00 m

Total screen height = curtain height - elevation Z + screen height above axis

This results in **minimum** dimensions of **3.75 m wide by 5.0 m high** (4.0 m - 2.0 m + 3.0 m) for the terminating screen.

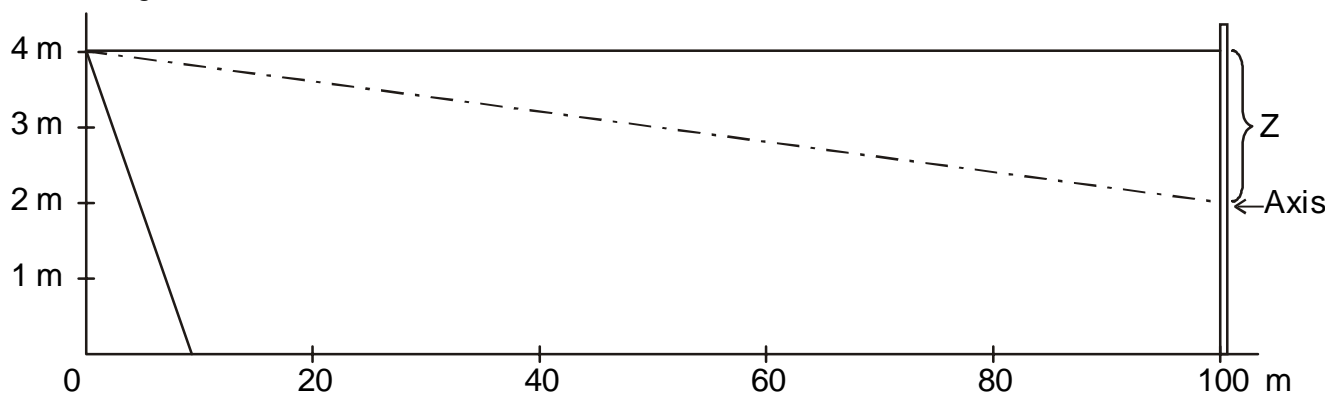

Typical side view of a terminating screen in 100 m distance from the detector. The dimension „Z“ is app. 2.0 m corresponding to the value of the table in section 5.

Required Properties of a Terminating Screen

The material of the screen has to block the thermal infrared radiation in the first place. Additionally it should be non-reflecting and thermally insulating to avoid unwanted signals from reflected heat sources and secondary radiation from strong sources heating up the screen from behind.

Since smooth surfaces – although dull for visible light – reflect the longer wave-length radiation of the thermal infrared much better, a rough or structured surface has to be used.

Wood has all the required properties if the surface is treated according to the recommendation but almost any plastic material would be suitable. If in doubt about thermal transmission verify the performance with tests or consult the manufacturer.

Reflections from Screen and Ground Surface

Special attention has to be taken to possible reflections from the rising or setting sun which may generate strong signals together with fast moving clouds. In cases where the screen is facing sunrise or sunset at any time of the year the top of the screen has to be tilted towards the detector to reflect the sun into the ground.

The ground has to be as non-reflecting as possible even when wet, use proper drainage to avoid forming of puddles. Reflections from snow can not be avoided technically and an increased occurrence of nuisance alarms while the ground is covered with snow has to be accounted for.

Recommended Screen Dimensions

The following table indicates recommended values for the dimensions of a terminating screen in function of the distance.

Depending on the nature of possible nuisance alarm sources behind the screen, larger dimensions have to be chosen (e.g. sources with strong thermal contrasts like heavy vehicles, trains or aeroplanes) to avoid unwanted alarms.

Distance X	Recommended screen width	Recommended screen height above axis
25 m	1.00 m	0.75 m
50 m	2.00 m	1.50 m
75 m	3.00 m	2.25 m
100 m	4.00 m	3.00 m
125 m	5.00 m	3.75 m
150 m	6.00 m	4.50 m

Annex 3: Installation Tester IT 44 and PIRScope

Introduction

The universal Installation Tester IT 44 is available as accessory for alignment, setting up and fault finding and can be used with all analog or digital detectors. It is recommended for verification of all installations in order to optimise the performance of the detectors.

The following describes the features of the IT 44 and the software program for signal display.

It is strongly recommended that the detection performance of the detector is verified by using the IT 44 Installation Tester. The IT 44 is connected to the detector's test connector from which it receives power and data without interfering with the detector's operation.

The IT 44 displays all relevant detector data on a 4 - line liquid crystal display (LCD) including signal amplitudes with peak-hold and the alarm threshold level. This level is dependent on the amount of disturbance signals including walk tests.

Connection / Reset

The IT 44 is supplied with a cable of app. 3 m length terminated with a 7 pole circular connector. An adapter cable for connection to the detector's in line connector is supplied with the IT 44.

When connected to the detector the IT 44 will be powered, start operation and display the identification of the Installation Tester „**IT 44**“ including its version (e. g. „V 0.2“) on line 1 as well as „**Analog Mode**“ on line 3 for a short period of time. The same display will appear every time RESET is pressed.

Liquid Crystal Display

The display is divided into 4 lines providing the following information:

Line 1: Signal and Peak Hold

Quasi-logarithmic bar display in 60 steps shows the signal strength. The peak amplitude of each signal exceeding the internal noise amplitude by a certain value is maintained for app. 6 s.

Line 2: Alarm Threshold Level

Displays the instantaneous alarm threshold level in the same scale as in line 1. If the ATD of the detector is enabled the alarm threshold level will be increased by signals caused by turbulences and walk tests.

Line 3: Alarm Indicator and Counter

Displays „**Alarm ON**“ or „**Alarm OFF**“ and the number of counts since last reset (display of „**Count:**“ and „**0**“ to „**99**“ or „**-**“ if 99 counts have been exceeded).

Line 4: Alarm Time

Displays the alarm time for each event with „**Time**“ and e.g. „**12.3 s**“. The alarm time depends on the actual alarm duration plus the setting of the alarm time potentiometer.

Audible Alarm

The Installation Tester has a high efficiency sounder which allows checking of the installation by a single person. This is engaged by operating the toggle switch on the side of the IT 44.

Digital Output

The digitised detector information is available on a RS 232 interface on a test connector at the side of the IT 44 for display on a PC screen with the **PIRScope** software.

No attempt should be made to make other use of this connector without instructions.

Application of the IT 44

The IT 44 is a most useful tool for checking the alignment and sensitivity setting of the detectors. It greatly facilitates the optimisation of an installation to suit a particular site.

The IT 44 is particularly helpful in situations where a detector is operated under conditions near the recommended operating limits of height, detection range and target speeds. The information supplied by the IT 44 display should be used to monitor the detection performance of the detector and make adjustments if required.

Depending on the site's animal activity, vegetation moving in the wind and/or other sources of disturbance it is possible that unwanted alarms occur. Monitoring and interpreting the information supplied by the IT 44 will help finding the best solution either by adjusting the alignment and/or sensitivity of the detector or by removing disturbance sources from within the field of view.

PIRScope Software for PIR-150

For Display of Signals on a PC Screen Using the IT 44 as Interface Unit.

Procedure

1. Connect the PIR-150 to power and connect the IT 44
2. Connect the IT 44 output with COM port of the PC
3. Load the file „PIRSCOPE.EXE“, enter language and number of COM port
4. Adjust display using the keys as defined on screen
5. Display will show signal amplitude (green), threshold (red) and alarm output (yellow)
6. Press „H“ to save a display in the active directory. A file will be generated and saved as „DDMMYYAB.BMP“ where AB are used for identification of files within one day.

Note

- When walk testing the PIR-150 make sure that the **ATD (Adaptive Threshold Decoding) is deactivated (switch closed)**, otherwise the detection will become poor due to gradual increase of the threshold.
- Running „PIRSCOPE.EXE“ under Windows may lead to problems therefore exit Windows and **start computer under DOS** to run the program.