

Ernitec Mercury SX 302

Full HD vandal dome IP Camera



- > Resolution up to 1080p
- > 3-9mm dc iris Lens
- > Built-in IR illuminator
- > Mechanical IR-cut
- > Edge storage
- > H.264 Main and High profil
- > Power over Ethernet (IEEE 802.3af)
- > 4 year Warranty

Mercury SX 302 intuitive design and the click-out electronics module is design with the installer in mind, while setup and programming are quickly accomplished using a browser interface. Remote health checks and software upgrades also ensure easy maintenance, as well as the highest reliability and system integrity.

The Mercury SX 302 can be installed virtually anywhere using POE, AC or DC power, the advanced CMOS progressive scan sensor technology provides outstanding images in both normal and difficult lighting conditions by automatically adjusting white balance to ensure accurate color reproduction Mercury SX 302 transmitting crystal clear images in real time Full HD format is made possible through the use of highly efficient H.264 compression, which can result in bandwidth and storage savings of as much as 80 percent compared to M-JPEG and 50 percent compared to MPEG-4 (Part 2) compressions.

The Mercury SX 302 can encode dual H.264 and M-JPEG streams simultaneously in real time to address different live or recording applications.

The OnVif compliant APIs provide the necessary flexibility to ensure compatibility with most OnVif supported VMS platforms

Technical Specification – Ernitec Mercury SX302p

Camera

Camera type	Vandal Dome day / night (ICR Type)
Effective Pixels	1920 (H) x 1080 (V)
Image Sensor	1/2.7" Progressive CMOS
Electronic Shutter Speed	1~1/10.000 sec.
Min. Illumination	0.2 Lux (Color), 0.0001 Lux (B/W), F1.2, 30IRE
Day/night switching	Mechanical IR-cut

Lens

Lens type	Manual focus
Focal Length	3 ~ 9 mm
F. number	F1.2 (wide)
Iris	DC iris
FOV	103.5° (Wide) ; 34.3° (Tele)

Video

Video Compression	H.264/MJPEG
Video stream	Dual / 1080p@25fps H.264 + D1@25fps H.264/MJPEG
Resolution	Full HD1080p/ SXGA/ HD720p XGA/SVGA/ D1/ VGA/ CIF
Brightness	Manual
Exposure	Auto / Manual
Sharpness	Manual
Contrast	Manual
White Balance	Manual / AWB/ ATW
Saturation	Manual
Hue	Manual
Digital Zoom	Yes
WDR	On/Off
3D Noise	On/Off
Privacy Zone	On/Off
Motion detection	On/Off
Tampering Alarm	On/Off

Network

Network Interface	Ethernet (RJ45) 10/100Mbps
Supported protocol	IPv4/v6, TCP/IP, UDP, RTP, STPS, HTTP, HTTPS, ICMP, FTP, SMTP, DHCP, PPPoE, Upnp, IGMP, SNMP, QoS
Internet Browser	Internet Explorer (6.0+), Chrome, Firefox, Safari
Password Levels	User / Administrator
User Account	20
Event Notification	HTTP, FTP, SMTP

General

Onvif	yes, se more information on www.onvif.org
Edge Storage	SD/ SDHC card slot (card is not included)
Audio	Two-way /G.711 /G.726
Audio input / output	4 pins terminal block
Digital In/out	1 /1 (4 pins terminal block)
Analog Video Output	1Vpp, 75Ω, PAL BNC connector class 2
Power Voltage	12VDC / 24VAC/ POE (IEEE802.af)
Power Consumption	Max. 8.9W / with heater 25.2W
Power Connector	3 pins terminal block / RJ45
Fan & Heater	Yes, 16.1W (12VDC/ 24VAC only)
Environmental Casing	Weatherproof IP66/ Vandal proof up to 661.2KgF
Languages	English, French, German, Italian
Operating Temperature/Humidity	-40°C ~ +50°C / 10% ~ 90% RH
Dimensions	Ø151 x 130,25mm
Weight (Net)	Approx. 900g
Warranty	4 years
Included accessories	Installation and Management software DVD
Part number	0070-04302

Optional accessories

1ch video management software	0063-99999
AppView for smart phones and tablet	free download

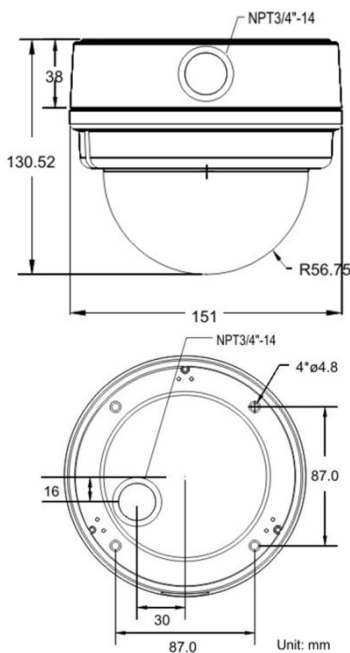

DISTRIBUTED BY

