

Installation Manual

Ernitec Eagle PIR-100 & 100H

Long-Range Curtain

Detectors for Perimeter Protection Outdoors

Version 2.0 and higher

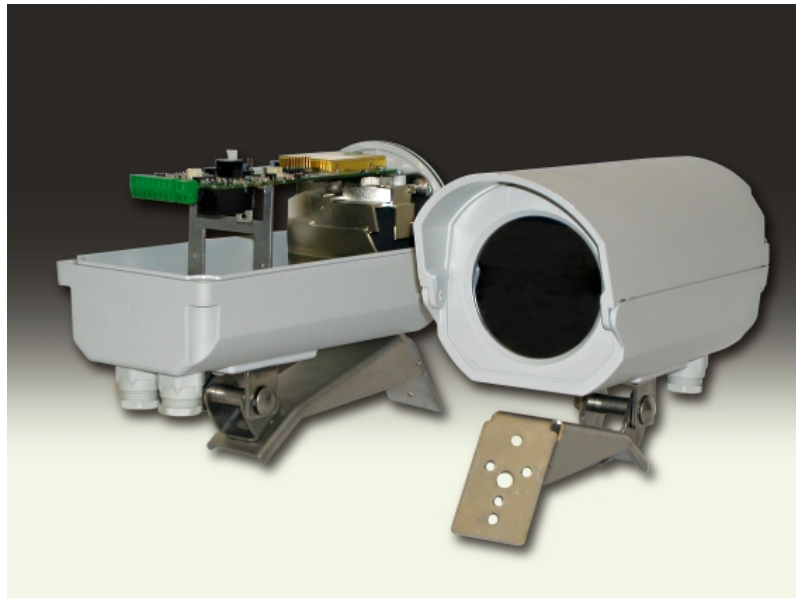

06/2008

Standard Models

- **PIR-100 Standard**
Nominal Range 120 m (400 feet)
- **PIR-100H High Performance**
Nominal Range 150 m (500 feet)

Highlights

- Gap-Free Coverage with Creep Zones
- 4 Meter (13 Feet) Mounting Height
- Advanced Tamper Detection
- Low Power Consumption – Ideal for Wireless and Solar Applications
- Wide Power Supply Range
- Heater & Heavy Duty Front Window (H version only)
- Integrated Bracket for Wall Mounting
- Remote Configuration and Alarm Management

www.ernitec.com

Table of Contents

Page

Standard Models	1
Highlights.....	1
1 Introduction.....	4
2 Mounting and Installation	4
3 Connecting the PIR.....	4
4 Field of View.....	5
5 Alignment	5
6 Sensitivity Settings for Range and Mounting Height	6
7 Adaptive Threshold Discrimination (ATD)	6
8 Anti Vandal Function.....	7
9 LED.....	7
10 Alarm Management.....	7
11 Alarm Time	7
12 Internal Temperature Compensation	7
13 Internal Heater (H version only)	7
14 External Sensitivity Adjustment via RS 485 Data Bus	8
15 Signal Processing.....	8
16 Accessories.....	8
16.1 Interface Module PIRIF 485/2 and Installation Software	8
16.2 Pole Mount Hardware ZA P-L1	8
17 Maintenance	9
18 General Comment on the Eagle PIR	9
19 Appendix Electronic Board and Terminal Block.....	10
19.1 Terminal Block	10
19.2 Dip Switches	10
20 Appendix Two Way Communication RS 485.....	11
20.1 Introduction	11
21 Appendix Installation Software	11
21.1 Introduction	11
21.1.1 Application of the Installation Software	11
22 Appendix Specification	12
22.1 Mechanical Dimensions.....	12

Installation and Maintenance

1 Introduction

The PIR is a highly sensitive Passive Infrared Detector designed for detection outdoors with a narrow, curtain-shaped differential field of view. It incorporates microprocessor-controlled signal processing including signal shape analysis, adaptive threshold level by feedback of environmental effects, temperature compensation and rejection of disturbance signals.

Sensitivity adjustments are done with DIP-Switches for each individual unit in function of the required detection range in order to adapt to the specific needs of an installation.

In addition to the hardware settings, adjustments can be made in a two way communication mode and signals displayed on a PC screen by using the optional installation software and RS 485 communication interface module.

2 Mounting and Installation

The mounting structure should be stiff enough and resist to significant deflections in windy conditions. Movement of the PIR caused by vibrations or other movements will result in swings of the field of view covered by the PIR and could cause disturbance signals. These unwanted signals may lead to an increase of the alarm threshold level which reduces the detection probability or in certain cases can lead to unwanted alarms.

The stainless steel bracket is ideally suited for wall mounting (using screws). For pole mounting the original accessory ZA P-L1 is available (pole mounting bracket with two strap bands for poles of 4 – 16 cm diameter). For further information please refer to 16.2.

- It is very important that the cover of the detector is securely tightened. It must be tightened with the two screws to the point where it cannot be closed further with reasonable force. There will then be hardly any gap between the cover and the bottom part of the housing (considerably less than 1 mm).

The detectors are fitted with two cable entry assemblies of M16. The nut on the cable entry assembly should be tightened to clamp the cable in place with reasonable force. If the cable diameter is too small to be held properly, insulation tape should be wound around the cable to increase the outside diameter to a suitable size.

3 Connecting the PIR

For the definition of the electronic board and terminal block see appendix 19.1.

Alarm Signalling

There are three types of alarm signalling from the PIR:

- one SPST potential-free relay contact
- one open collector transistor output
- an RS 485 two way communication link (see appendix 20 for details)

With the detector in factory setting the relay contact opens and the transistor switches to low resistance on alarm. Output logic and function can be changed using the installation software.

During turn-on time the relay output is in alarm state!

Cover Switch

To detect attempts to open the detector, a switch is fitted for the cover. Its contact opens when the cover is opened.

4 Field of View

The PIR has two curtain-shaped fields of view with independent detection channels for short, medium and long range detection. The vertical opening angle is app. 26° resulting in an uninterrupted curtain starting at app. 8 m with the detector mounted at 4.0 m (13 ft) height. The nominal ranges and widths at nominal range refer to the table below.

Definition	PIR-100	PIR 100H
Nominal Range	120 m (400 feet)	150 m (500 feet)
Width at Nom. Range	2.7 m (9 feet)	3.3 m (11 feet)

5 Alignment

The detection range of a PIR detector is not limited but a function of size, speed and temperature contrast of a target against its background. The PIR should be aligned so that a natural or artificial background at the end of the range terminates the field of view.

Vertical alignment is optimal when the upper edge of the field of view is at 1.5 to 2.5 m (5 to 8 ft) above ground at the end of the required detection range provided that the field of view is properly terminated.

Coarse alignment can be done visually by looking along the groove on the top of the detector. This line of sight corresponds to the upper edge of the detection pattern. Accurate fine alignment is easily achieved with the help of the Universal Telescopic Sight ZA P 03, which can be placed on the top of the detector for this purpose.

Where the detection range has to be limited, a terminating screen can be used to avoid detection of targets beyond the wanted range.

Typical vertical alignment for a required detection up to nominal range.

The PIR should be aligned vertically so that **at least** the lower half of a person standing upright at the maximum required range will be within the field of view (see Fig. 1 below).

Side view

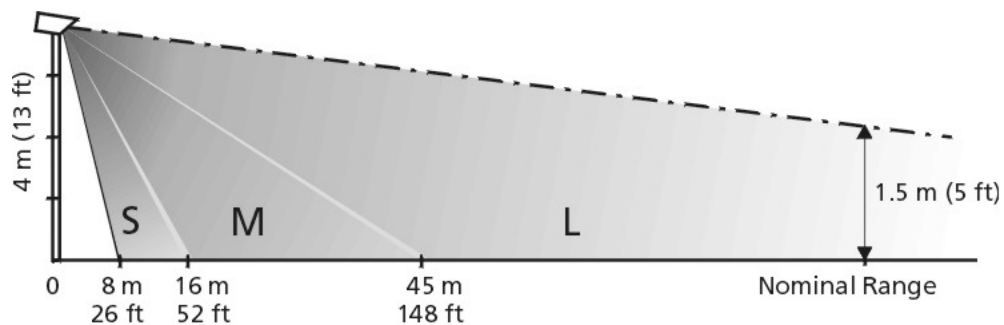

Fig. 1

Typical horizontal alignment

Horizontal alignment should be done in a way to avoid unwanted signals being generated by targets (branches, bushes, fences) likely to be moved by wind (see Fig. 2 below). Movement within the field of view will reduce the sensitivity of the PIR by increasing the alarm threshold level and may lead to unwanted alarms.

Top view

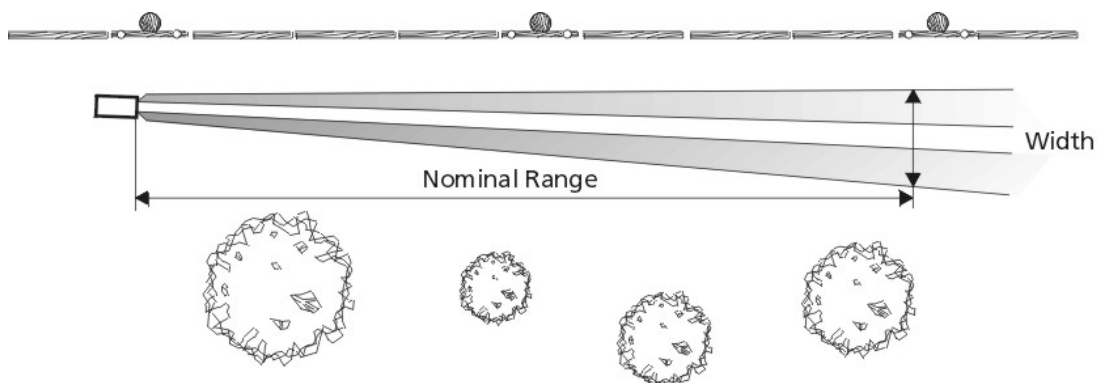

Fig. 2

6 Sensitivity Settings for Range and Mounting Height

The various settings of the PIR are made by means of multiple DIP - Switches on the printed circuit board.

The **DIP – Switches 1 and 2** are for **sensitivity setting** depending on the required detection performance. If the maximum required range is less than the nominal range of the detector, it is recommended to reduce the overall sensitivity to reduce nuisance alarms.

Switch 1 and 2	PIR-100 Overall Sensitivity	PIR-100H Overall Sensitivity	
off – off	60 m	75 m	
off – on	84 m	105 m	
on – off	Max. Range	Max. Range	Factory Setting
on – on	Software Settings	Software Settings	

- *) With the **DIP - Switches 1 and 2** both set to „on“, the sensitivity can be adjusted with the installation software. If the sensitivity is adjusted with the installation software, **the programmed value will remain active also following a power off.**

The IR 454 / IR 464 is designed for mounting at heights between 2.5 and 4.0 m above ground. The **seventh DIP Switch** is used to set the relative sensitivity of all detection zones in function of the **mounting height** as recommended below:

Switch 7	Mounting Height	
off	„Low < 3.0 m“	
on	„High > 3.0 m“	Factory Setting

If the mounting height is less than 2.5 m, a detection gap at app. 10 m distance may be observed for fast movements. This is due to the overlap of the three zones and resulting rejection of simultaneous signals.

7 Adaptive Threshold Discrimination (ATD)

The background noise is constantly averaged and used to adjust the threshold levels for the alarm. This special feature is reducing the probability of nuisance alarms caused by wind, moving vegetation or objects that have a thermal contrast although usually weaker than a person.

Each signal exceeding a certain minimum value will activate the ATD and increase the threshold levels depending on its strength. The time constants for increase and decrease are chosen in a way to adapt to gradual changes. Signals generated by a person moving within the specified speed range, however, are strong enough for detection. Repeated movement of any kind within the field of view is therefore activating the ATD, reducing the overall sensitivity. This has to be noted particularly when walk testing the following installation.

The **DIP – Switch 3** is used to activate or deactivate the **ATD** (Adaptive Threshold Discrimination).

Switch 3	ATD	
off	off	*)
on	on	Factory Setting

- *) Operation of the PIR in this mode is possible but not recommended in outdoor applications as the nuisance alarm rate could increase significantly as a result of turbulences.

- When walk testing the unit, the threshold level will increase as a result of the signal generated by the target and decrease exponentially in time after the event. To make sure that original sensitivity is reached, wait at least for 3 minutes between each crossing or disable the ATD function by setting DIP - Switch 3 to „off“.

If the Installation software is used for monitored walk tests and the DIP – Switches 1 and 2 are set to software settings (on – on), the threshold level can be kept to its nominal value by changing the configuration of the ATD to „off“ for this test.

8 Anti Vandal Function

The PIR is equipped with a sophisticated **protection against vandalism**. These detectors can sense certain changes of their alignment from the original position as set during the installation. A change of the detector's alignment generates a permanent alarm **until the detector's alignment is back in its original position or until the position has purposely been reset**.

When using the alarm management with RS 485 communication a vandal alarm will be identified separately.

After the turn-on time of typ. 60 seconds from power on, the detector determines and stores its alignment position (only with detector cover closed).

After opening and closing the cover with the unit powered on, the detector determines its alignment position and stores the position value after 5 minutes again without having the detector in permanent alarm state.

The anti vandal sensor can be reset remotely with the setup program (takes app. 10 seconds) or with a power off-on (60 seconds).

Hardware Mode:

When operating the detector in the HW mode, the anti vandal function is activated by setting DIP – Switch 6 to „on“.

Switch 6	Anti Vandal Function
off	off
on	on

Factory Setting

Software Mode:

Operating the detector in the SW mode, the anti vandal function is activated by means of setting of the corresponding parameter in the settings of the setup program to „on“.

9 LED

The electronic board is fitted with a dual LED having a red and green colour side. This can be monitored during installation while the cover is open.

- The red LED indicates whether the detector is in alarm state or not
- The green LED flashing at 2 Hz frequency indicates the detector ready state.

During the turn-on time the red LED is on.

10 Alarm Management

The PIR features an alarm management function over RS 485 communication. All the detectors connected to the same data bus provide all the information relevant to an alarm in a defined protocol frame. For further information please contact the manufacturer.

11 Alarm Time

Alarm time per event is determined by the duration of the detected event and depends on the shape and amplitude of the alarm signal. Individual alarm pulses have a minimum time of app. 2.5 s.

12 Internal Temperature Compensation

The PIR is detecting radiation differences of a target against its background. In the course of the day and year the contrast of a person will vary considerably and affect the signal strength. To compensate for this contrast variation, the PIR has internal temperature compensation with maximum sensitivity at app. 30°C (where the contrast of a human target is weakest) and gradual reduction at higher and lower temperatures.

- When installing a unit the internal temperature may take up to 30 minutes or more to stabilise to the actual external temperature. Sufficient time should be given to the PIR to reach the correct internal temperature and sensitivity before performing walk tests.

During the initial period of operation it is strongly recommended that walk tests are repeated and signals monitored under various weather conditions such as high and low temperatures, wind fog, snow, rain etc. to obtain comparative data and information on the effects of environmental conditions on detection and nuisance alarm probabilities for this particular site. Fine-tuning of the detector based on this data by changing the sensitivity settings may optimise the performance.

13 Internal Heater (H version only)

A regulated heater connected to the electronic board and powered by the supply voltage of the PIR-100H prevents the optical surfaces from fogging or frosting and maintains the internal temperature at optimal levels.

14 External Sensitivity Adjustment via RS 485 Data Bus

If the **DIP - Switches 1 and 2** are both set to „on“, the detection performance can be adjusted via the RS 485 two way communication port. Range sensitivity of the model PIR-100 can be set to values between 60 m and maximum, and model PIR-100H to values between 75 m and maximum. In addition to this, the overall sensitivity can be fine adjusted by using the software sensitivity button.

The external sensitivity adjustment may also be used if overall sensitivity has to be changed at certain periods of the day or year depending on the prevailing thermal contrasts. Field tests in the actual environment will determine the optimum settings.

15 Signal Processing

The sophisticated signal processing ensures an optimum performance and reliability of the detector.

The background noise is sampled and averaged over a large number of cycles giving a noise dependent value for the alarm threshold and to start the adaptive signal shape analysis whenever a certain amplitude value is exceeded. If the threshold has temporarily been increased by high background noise or repeated movements in the field of view, the exponential decay of the threshold level to its original value will take app. 1 ... 2 minutes from the end of the event.

Once the threshold level value has been exceeded, the microprocessor starts its signal shape analysis routine where a number of interdependent parameters are calculated and analysed.

Only if a signal meets all the predetermined criteria an alarm will be generated.

16 Accessories

16.1 Interface Module PIRIF 485/2 and Installation Software

The Installation Software is very useful for alignment and signal check during setting up and routine maintenance. It will indicate the amplitudes generated by wanted as well as unwanted targets and help setting the gain control correctly during walk tests and also show the magnitude of disturbance signals. The installation software is to be installed on a PC; an interface module is required to convert RS 232/USB to RS 485. The information for installation and signal monitoring is displayed on the screen of the PC.

If more than one detector is connected to the same RS 485 communication bus, each detector needs to have a different address (ID).

Please see the PIRIF-485/2 Installation and Setup Manual, for further details.

16.2 Pole Mount Hardware ZA P-L1

Pole mounting bracket with two strap bands for poles of 4 – 16 cm diameter



17 Maintenance

The detector has been designed to be virtually maintenance free but the following precautions are recommended:

- 1) **Visual inspection of the front window** for accumulation of dirt on the outer surface or damage at intervals of app. 6 months. Clean the surface with a paper tissue and avoid rubbing dirt into the surface. Use the same precautions as for a camera lens.
- 2) **Walk tests** for checking the detector alignment and sensitivity settings to ensure optimal performance and reliability.
- 3) **Inspection is recommended following extreme conditions** such as snow storms, sand storms, hail etc. to make sure that nothing has been damaged and the sensitivity is not reduced by accumulation of snow, sand or dirt on the front window. Snow or dust in front of the window should be removed by hand or by using of a soft instrument (e.g. a wooden stick).

18 General Comment on the Eagle PIR

- Despite the advanced design and state-of-the-art features of the PIR it is in the nature of a Passive Infrared Detector that an absolute detection probability and freedom from nuisance alarms cannot be achieved, **masking of the PIR cannot be excluded**.
- Detection is a function of thermal contrast, speed and size of a target crossing the field of view. Contrast conditions can vary significantly in the course of the day and year.
- Detection depends also on the sensitivity settings, the exact aiming and the prevailing weather conditions as well as the nature of the target and background.
- The detection pattern and frequency response of the PIR has been optimised for the detection of human size targets crossing the field of view in an upright position at speeds in the range of 0.2 ... 5.0 m/s.
- Detection of slow moving targets at long range may become uncertain under weak contrast conditions. It is strongly recommended to limit the zone length to less than the nominal range when human targets moving at the minimum specified speed need to be detected with high probability.
- Animals or crawling people may or may not be detected depending on their size, speed, contrast and distance from the detector.
- It is therefore strongly recommended to **combine the PIR with alarm verification** such as CCTV or a second system using other physical means of detection (e.g. VMD).
- Any liability for direct or indirect damage resulting from the use of the PIR as a detection device is explicitly disclaimed.
- The information in this product manual is based on testing of samples taken at random from production and believed to be representative, E&OE.

19 Appendix Electronic Board and Terminal Block

Top View

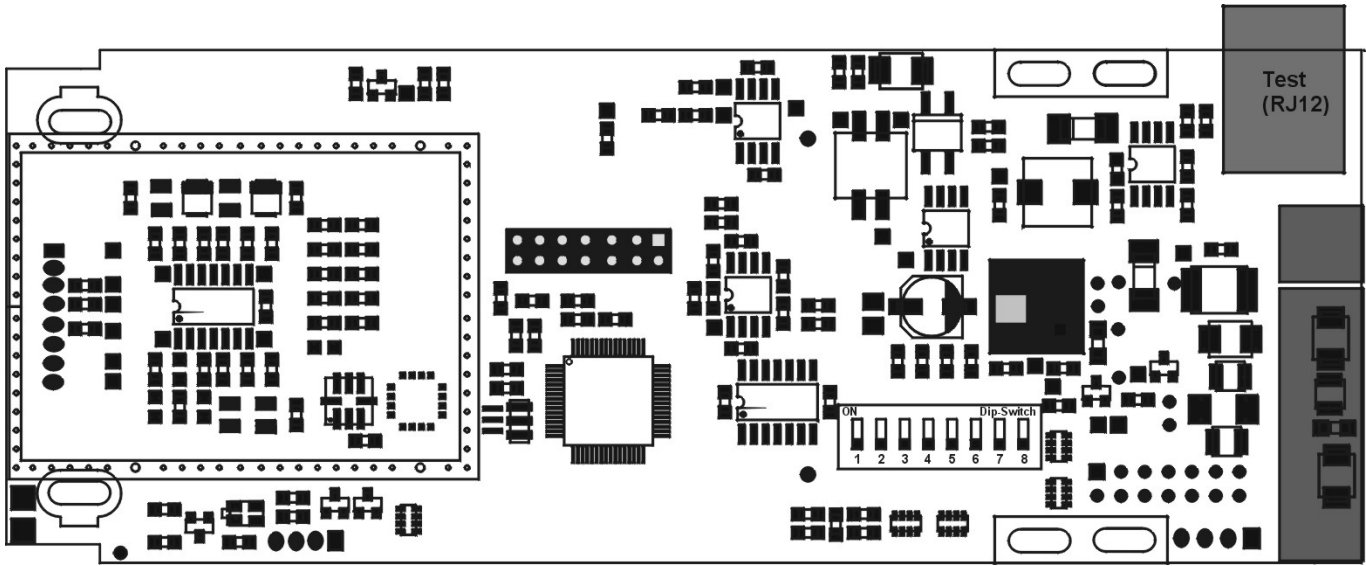

19.1 Terminal Block

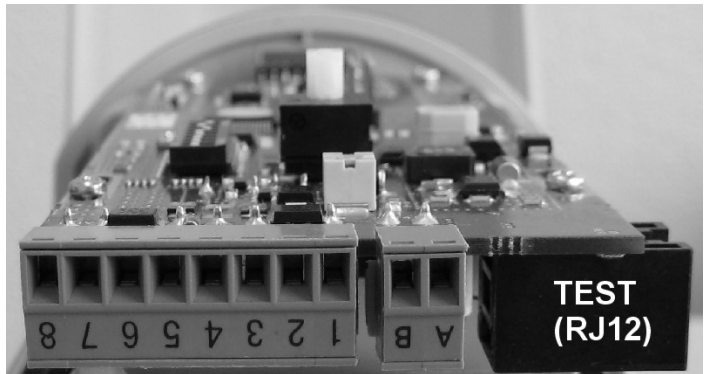
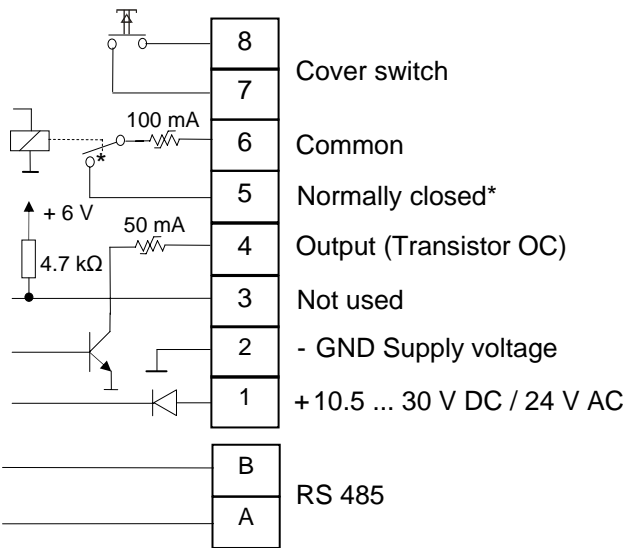

* Relay shown in energised (non-alarm) condition

19.2 Dip Switches

Sensitivity

SW1	SW2	PIR-100	PIR-100H
ON	ON	SW settings	
ON	OFF	HW setting maximum range	
OFF	ON	HW setting 84 m	HW setting 105 m
OFF	OFF	HW setting 60 m	HW setting 75 m

Function Switches

SW	Function
3	ATD
4	Not used
5	Not used
6	Anti-vandal function
7	Mounting high / low
8	Not used

20 Appendix Two Way Communication RS 485

20.1 Introduction

The PIR is equipped with an RS 485 interface for two-way communication between the detector and a PC or other control device. This communication link is used for detector set-up and remote adjustments as well as for signal monitoring.

It can either be used temporarily for installation or permanently wired for remote access to the detector from the control room. RS 485 can accommodate up to 32 detectors on the same data bus with a maximum bus length of 1'000 m – provided the detectors have all different IDs and the data bus is properly terminated at both ends. There is no terminating resistor built into the detector. **The last detector on the bus**, on the opposite side of the IF 485B interface module, needs a **terminating resistor of 120 Ω**. This can be accomplished by adding a resistor between the **wires RS 485 A and RS 485 B**.

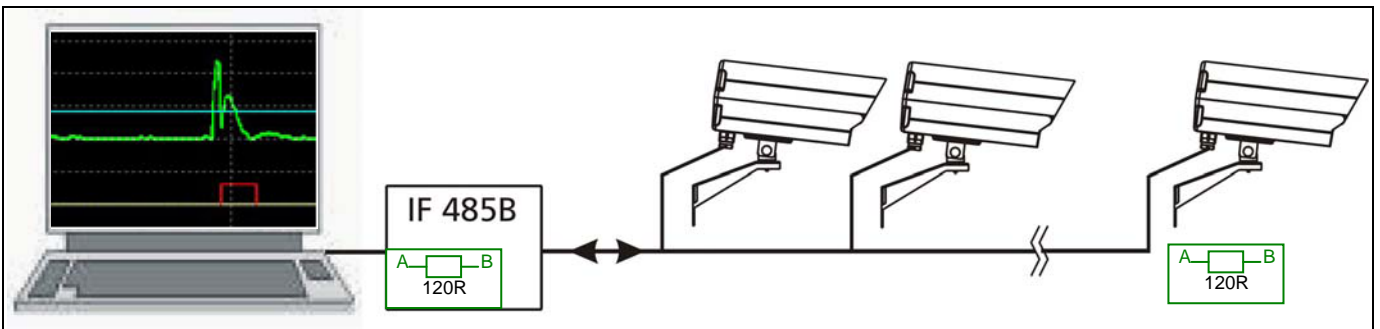

Please see the PIRIF-485/2 Installation and Setup Manual, for further details.

21 Appendix Installation Software

21.1 Introduction

The installation software is available as accessory for alignment, setting up and fault finding. It can be used for **remote programming** and **verification** of all detectors connected to the same RS 485 data bus and is recommended for verification of all installations in order to optimise the performance of the detectors. If more than one detector is operated over the same communication link it is necessary that the detectors have different addresses (IDs).

For operation with a standard PC a converter to RS 485 is required. The interface box is available as accessory.

21.1.1 Application of the Installation Software

The installation software is a most useful tool for remote programming and for checking the alignment of the detectors. It greatly facilitates the optimisation of an installation to suit a particular site.

Independently of the position of DIP-Switches 1 and 2 (hardware or software settings) the program is capable to display the actual parameter settings as well as the analog signals of the selected detector.

For **remote programming** purposes the **DIP-Switches 1 and 2** have to be switched to **on-on** position (software settings). Now all parameter settings can be altered with the software.

The software is particularly helpful in situations where a detector is operated under conditions near the recommended operating limits of height, detection range and target speeds. The information supplied by the PC display should be used to monitor the detection performance of the detector and make adjustments if required.

Depending on the site's animal activity, vegetation moving in the wind and/or other sources of disturbance it is possible that unwanted alarms occur. Monitoring and interpreting the information supplied by the installation software will help finding the best solution either by adjusting the alignment and/or settings of the detector or by removing disturbance sources from within the field of view.

Please see the PIRIF-485/2 Installation and Setup Manual, for further details.

22 Appendix Specification

Model	PIR-100	PIR-100H
Optical		
Nominal Range	120 m (400 ft)	150 m (500 ft)
Width @ Nominal Range	2.7 m (9 ft)	
Mounting Height	2.5 ... 4.0 m (8 ... 13 ft)	
Detection Speed	0.2 to 5 m/s (0.7 to 17 feet/s)	
Sensors	Pyroelectric, differential triple channel	
Spectral Response	8 – 14 μ m, double filtering	
Optics	Segmented precision mirror	
Front Window	Plastic, IR transmissive	Silicon wafer
Sensitivity Adjustment	DIP switches and RS 485	
Mechanical		
Case Material	Heavy duty plastic	
Colour	white	
Weight	app. 900 g (2.0 lbs), incl. mounting bracket	
Cable Feeds	2 x M 16 with cable clamp	
Outer Cable Diameter	4.5 ... 10 mm (0.18 ... 0.40 inch)	
Electrical		
Supply Voltage	10.5 ... 30 V DC / 24 V AC (\pm 15%)	
Current Consumption	typ. 18 mA @ 12 V DC typ. 10 mA @ 24 V DC	PIR-100 specs. + Heating Power @ -40° C (F) max. 2 W
Alarm Relay Output	SPST rated 30 V DC, max. 100 mA	
Transistor Output	Open collector NPN, 30 V DC, max. 50 mA	
Cover Switch	30 V DC, 100 mA	
Turn-on Time	typ. 60 seconds from power on	
Communication	Bi-directional RS 485 @ 9'600 baud	
Test Socket	✓	✓
Wiring Terminal Block	0.34 mm ² ... 1.5 mm ² (AWG 28 ... 16)	
Environmental		
Operating Temperature	-20° C ... $+60^{\circ}$ C (-4° F ... $+140^{\circ}$ F)	-40° C ... $+60^{\circ}$ C (-40° F ... $+140^{\circ}$ F)
Humidity	95 % RH max.	
Sealing	IP 64 splash proof	

22.1 Mechanical Dimensions

