

Hyperion Twin

Infrared LED Illuminator

ernitec



High Power

The latest smt led technology dare high performance and low power consumption

Adjustable angle aim point

The innovative beam angle calibration system permits a fine and accurate aim point

Integrated power supply and twilight

The integrated constant current power supply and photocell circuit allow a quick and easy installation without external box

Moulded full Aluminium body

The sturdy Aluminium body and cable management guarantees vandalproof performances as well as heat dissipation



MODELS

ORDER CODE	Beam Angle	Field of View: Max Distance x Arc Width		IP Rate	Power supply	Cable Management
HYP 15 HI	15°	250 x 65 m	(273 x 72 yd)	IP66/67	Internal 230 V~	●
HYP 30 HI	30°	200 x 105 m	(219 x 114 yd)	IP66/67	Internal 230 V~	●
HYP 60 HI	60°	150 x 157 m	(164 x 172 yd)	IP66/67	Internal 230 V~	●
HYP 120 HI	120°	50 x 105 m	(55 x 114 yd)	IP66/67	Internal 230 V~	●
HYP 15 LOW	15°	170 x 44 m	(186 x 49 yd)	IP66/67	Internal 230 V~	●
HYP 30 LOW	30°	120 x 63 m	(131 x 69 yd)	IP66/67	Internal 230 V~	●
HYP 60 LOW	60°	80 x 84 m	(87 x 92 yd)	IP66/67	Internal 230 V~	●
HYP 120 LOW	120°	40 x 84 m	(44 x 92 yd)	IP66/67	Internal 230 V~	●

RELATED PRODUCTS

PA/1 Pole mount adapter for one bracket

PA/2 Pole mount adapter for two brackets

CM Corner mount adapter



SPECIFICATION

General

- Wavelength: 850nm semi-covert
- High efficiency SMT Leds
- PC optical beam collimator
- Aluminium die cast molding and Technopolymers
- Radiant body for optimal thermal yield

Mechanical

- Dimensions: 344 x 356 x 286 mm
- Angle adjustable:
Pan +10°/-30° (each module)
Tilt +45°/-15°
- Beam Pattern: see table

Electrical

- Power supply: 230 V~
- Power: 40 W (HI version)
26 W (LOW version)
- Adjustable Photocell circuit
- Dry contact for Day/Night camera switch

Environmental

- Indoor / Outdoor applications
- IP66 and IP67 weatherproof rating (EN60529)
- Temperature Range : -50°C to 50°C
- RoHS compliant
- CE

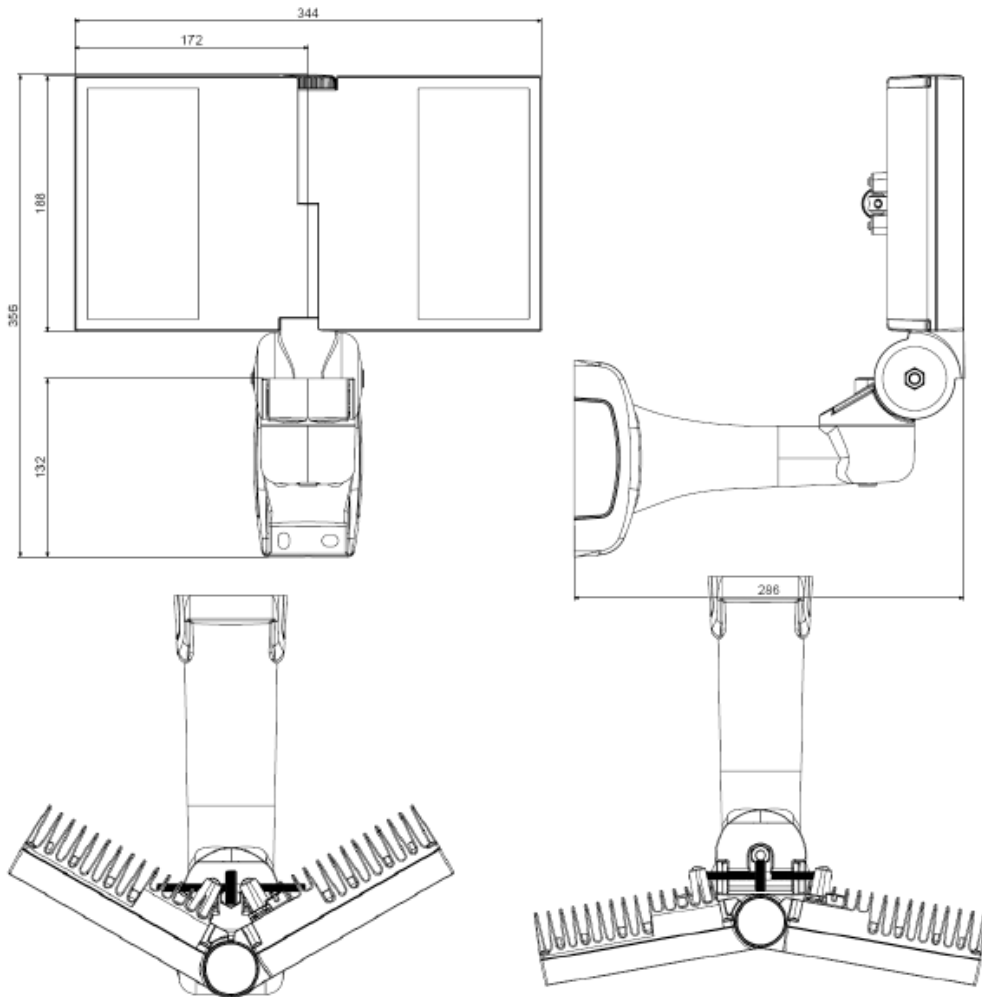

Note: Specifications subject to change without notice.

YOUR VIDEO SURVEILLANCE SUPPLIER

Ernitec A/S
 Phone: +45 44 50 33 00
 Fax: +45 44 50 33 33
 E-mail: info@ernitec.dk

Ernitec UK
 Phone: +44 (0) 1903 263 125
 Fax: +44 (0) 1903 263 126
 E-mail: info@ernitec.co.uk

Ernitec France
 Phone +33 (0) 4 67 15 10 15
 Fax +33 (0) 4 67 64 01 81
 E-mail: info@ernitec.fr

